

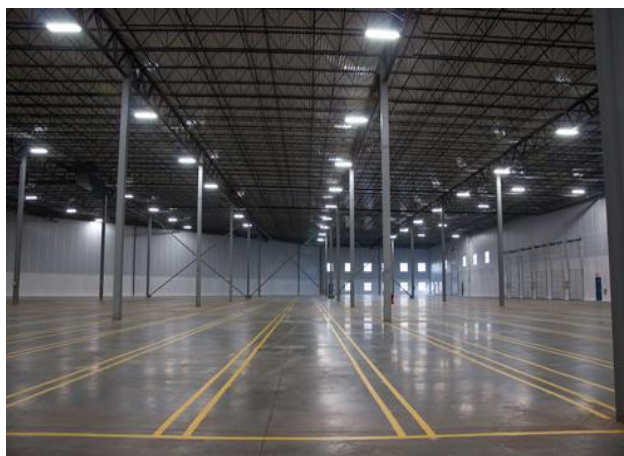



EO-HB-120



120 watt- LED Hi- Bay

SPECIFICATIONS	
Model Number	Product Code
Power Consumption	120 watts
LED Consumption	1 x 120watt Bridgelux
Driver	Meanwell
LED Initial Flux	7680 lumens
Average Lumens	6m - 27 lux 8m - 14 lux 10m - 9.6 lux
LED Luminous Efficiency	60-80 lumens / watts
Illuminated Area	At 6m - 18m diameter At 8m - 23m diameter At 10m - 29m diameter
Effective Beam Angle	120 Degree
Power Factor	0.9
Power Efficiency	>87%
Input Voltage	AC 220-265V
Lamps Efficiency	>91%
Storage Temperature	-25°C - +65°C (25°C)
Working Temperature	-40°C - +55°C
IP Rating	IP 65
Colour Temperature	6000 kelvin
Colour Index	>Ra75
Certificate	CS 9567N IEC 60598.2.1B IEC 61346.2.13:2006  N28689
Life Expectancy	50,000 +Hrs
Warranty	3 Years

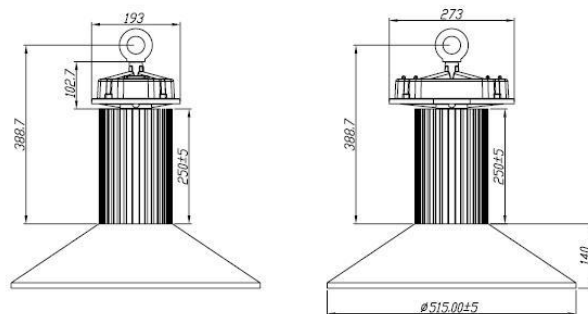

This product is eligible for the NSW Energy Savings Scheme

For more information visit our website: www.eolighting.com.au