

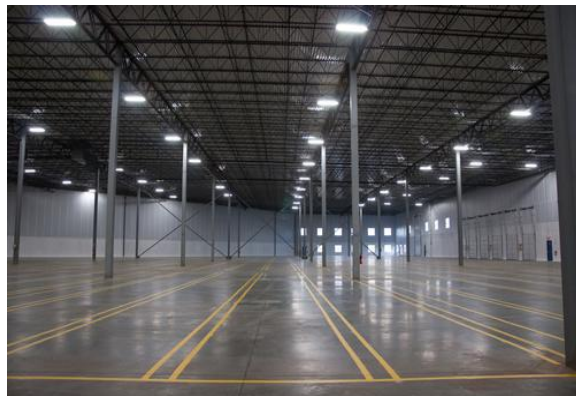

EO-HB-150



150 watt -LED Hi- Bay

SPECIFICATIONS	
Model Number	EO-HB-150
Power Consumption	150 watts
LED Consumption	1 x 150watt Bridgelux
Driver	Meanwell
LED Initial Flux	9400 lumens
Average Lumens	6m – 108 lux 8m – 61 lux 10m – 39 lux
LED Luminous Efficiency	60-70 lumens / watts
Illuminated Area	At 6m – 14m diameter At 8m – 18m diameter At 10m – 23m diameter
Effective Beam Angle	120 Degree
Power Factor	0.9
Power Efficiency	>87%
Input Voltage	AC 220 -277V
Lamps Efficiency	>85%
Storage Temperature	-25°C - +65°C (25°C)
Working Temperature	-40°C - +55°C
IP Rating	IP 65
Colour Temperature	6000 kelvin
Colour Index	>Ra75
Certificate	CS 9567N IEC 60598.2.1B IEC 61346.2.13:2006 N28689
Life Expectancy	50,000 + Hrs
Warranty	3 years

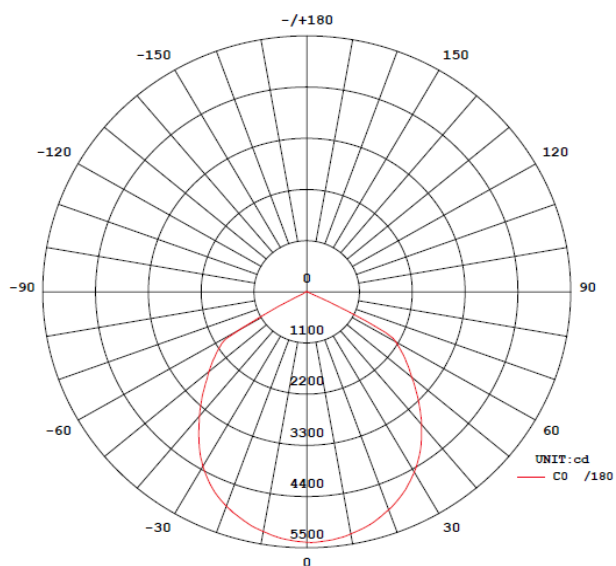
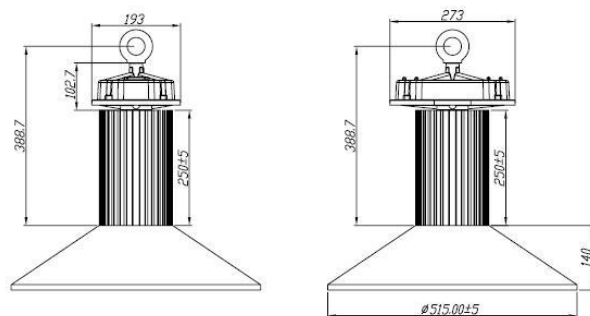

LUMINOUS INTENSITY DISTRIBUTION DIAGRAM

This product is eligible for the NSW Energy Savings Scheme

For more information visit our website: www.eolighting.com.au

© Summit LED Energy Australia Pty Ltd t/as eo lighting

Ph: 02 9653 9909 Fax: 02 9653 9959

Head Office Sydney: Unit 5G 256 New Line Road, Dural, NSW, 2158

Melbourne Sydney Canberra Adelaide Brisbane Perth