



EO-HB-80



80 watt -LED Hi- Bay

SPECIFICATIONS	
Model Number	EO-HB-80
Power Consumption	80 watts
LED Consumption	1 x 80watt Bridgelux
Driver	Meanwell
LED Initial Flux	>6,800 lumens
Average Lumens	4m – 180lux 6m – 98lux 8m – 65lux 10m – 46lux 12m – 20lux
LED Luminous Efficiency	85/100 lumens /watts
Illuminated Area	At 4m – 7m diameter At 6m – 11m diameter At 8m – 14m diameter At 10m – 18m diameter At 12m – 21m diameter
Effective Beam Angle	60/120/140° Degree
Power Factor	>0.9
Power Efficiency	>92%
Total Harmonic Distortion	≤8%
Input Voltage	240 Volts, 50 Hz
Lamps Efficiency	>92%
Storage Temperature	-25°C to + 65°C
Working Temperature	- 40°C to + 55°C
IP Rating	IP 40
Colour Temperature	6000 kelvin
Colour Index	>Ra80
Certificate	CS 9567N IEC 60598.2.1B IEC 61346.2.13:2006 N28689
Certificate	CE & ROHS & FCC & ISO.
Life Expectancy	50,000 + Hrs
Warranty	3 Years

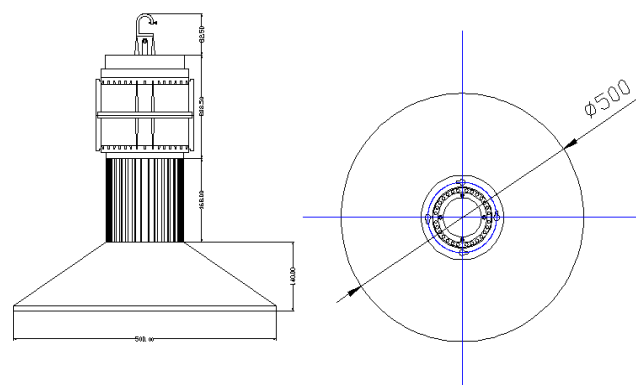

This product is eligible for the NSW Energy Savings Scheme

For more information visit our website: www.eolighting.com.au