

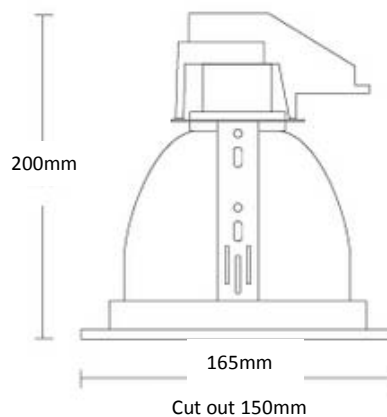

## EO- DL-PAR-150



| SPECIFICATIONS      |   |
|---------------------|---|
| Product Code        | Eo-DL -PAR-150  |
| Type                | Fixed Recessed Downlight                              |
| Colour              | Polished Silver with either Chrome or White Reflector |
| Lamp Base           | E27   |
| Suit lamp Type      | LED PAR20 LED PAR 38                                  |
| Operational Voltage | 240V  |
| Housing             | Aluminium & Thermoplastic                             |
| Net Weight          | 415g  |
| Cut Out             | 150mm   |
| Warranty            | 2 years   |



Specifications subject to change without notice

