



# EO-HB-200



## 200 watt -LED Hi- Bay

SPECIFICATIONS	
Model Number	EO-HB-200
Power Consumption	200 watts
LED Consumption	1 x 200watts Bridgelux
Driver	Meanwell
LED Initial Flux	>14,400 lumens
Average Lumens	4m – 515 lux 6m – 224 lux 8m – 132 lux 10m – 87 lux 12m – 49 lux
LED Luminous Efficiency	80 lumens / watts
Illuminated Area	At 6m – 23 diameter At 8m – 32 diameter At 10m – 41 diameter At 12m – 48 diameter
Effective Beam Angle	60,90,140 Degree
Power Factor	0.98
Power Efficiency	>90%
Power Factor	>0.98
Input Voltage	240 Volts, 50 Hz
Lamps Efficiency	>85%
Storage Temperature	-30c to 65c
Light Body & Lampshade Material	Aluminium House & AL Reflector
Working Temperature	-30C to 50C
IP Rating	IP 54
Colour Temperature	6000 kelvin
Colour Index	>Ra80
Certificate	CS 9567N IEC 60598.2.1B IEC 61346.2.13:2006  N28689
Life Expectancy	50,000 + Hrs
Warranty	3 Years

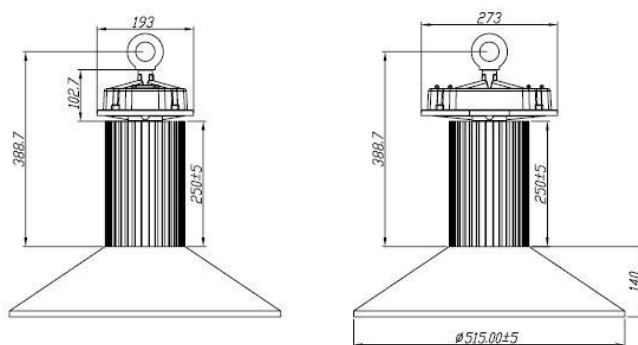

This product is eligible for the NSW Energy Savings Scheme

For more information visit our website: [www.eolighting.com.au](http://www.eolighting.com.au)

© Summit LED Energy Australia Pty Ltd t/as eo lighting

Ph: 02 9653 9909 Fax: 02 9653 9959

Head Office Sydney: Unit 5G 256 New Line Road, Dural, NSW, 2158

Melbourne Sydney Canberra Adelaide Brisbane Perth